

Max Air Heater

FOR SAFETY & LONG HEATER LIFE, CAREFULLY READ THIS MANUAL BEFORE USE.



Safety



SHOCK HAZARD!

Only qualified individuals should install this heater and related controls. Follow all applicable electrical codes and use proper wiring.



BURN/FIRE/EXPLOSION HAZARD!

Do not use in hazardous environments, and/or near explosive or reactive gases, or combustible materials. Avoid contact with the heater or exit accessories during or soon after operation. **DO NOT USE NEAR VOLATILE OR COMBUSTIBLE MATERIALS.**

Description

The Max provides a compact, efficient heater for heating air or inert gases up to 1400°F/760°C. The Max comes in various power ratings ranging from 6kW to 36kW. Two (2) type “K” thermocouples with a convenient terminal block are included for ease of wiring. One thermocouple measures inlet air temperature (S1) and other can be used for exit/process air temperature (S2). When powered and controlled with the Max Control Panel (sold separately) you are provided a convenient, cost effective solution for safely controlling the AC power to your Max. If operated correctly, the heater will operate continuously for 5000 hours or longer.

Specifications

Maximum Inlet Air Pressure	60 PSI (4 BAR)
Maximum Inlet Air Temperature	200°F (93°C)
Maximum Exit Air Temperature	1200°F (650°C) for 6kW to 10kW 1400°F (760°C) for 18kW to 36kW
Minimum Airflow (Recommended)	12 SCFM (340 SLPM)
Exit Air Connection:	1-1/2" FNPT
Inlet Air Connection:	1-1/4" FNPT
Safety Approvals:	CE, UL Recognized, CSA
Control/Limit Sensors:	Type “K” isolated, ungrounded, exposed junction TCs: S1 measures inlet temperature S2 measures exit temperature

General Information

Environmental Conditions:

Ambient Temperature	32°F to 104°F (0°C to 40°C)
Humidity	0% to 95% R.H.

Ventilation:

Use in a well-ventilated area away from excess dust, dirt, and moisture.

Cleaning:

With unit OFF and unplugged, exterior surfaces may be wiped clean using a dry, lint-free cloth.

Protective Earthing:

Each heater comes with a convenient grounding stud and hardware located at the inlet of the heater for protective means of earthing.

Heater Models and Parts List

Part Number	Maximum Wattage	Maximum Voltage	Maximum Amperage	Suggested wire size for 60°C cable*	Suggested wire size for 90°C cable*
F074723	6.0kW	240 – 1Ø 50/60Hz	25.0	12	12
F074724	6.0kW	240 – 3Ø 50/60Hz	14.5	12	12
F074725	6.0kW	380 – 3Ø 50/60Hz	9.1	12	12
F074726	6.0kW	480 – 3Ø 50/60Hz	7.2	12	12
F074727	10.0kW	240 – 1Ø 50/60Hz	41.7	10	10
F074728	10.0kW	240 – 3Ø 50/60Hz	24.1	12	12
F074729	10.0kW	380 – 3Ø 50/60Hz	15.2	12	12
F074731	10.0kW	480 – 3Ø 50/60Hz	12.0	12	12
F074732	18.0kW	240 – 3Ø 50/60Hz	43.4	8	10
F074733	18.0kW	380 – 3Ø 50/60Hz	27.4	10	12
F074734	18.0kW	480 – 3Ø 50/60Hz	21.7	12	12
F074735	30.0kW	380 – 3Ø 50/60Hz	45.6	8	8
F074736	36.0kW	480 – 3Ø 50/60Hz	43.4	8	10

* Follow applicable electrical codes during installation

Dimensions/Mounting

NOTE: The inlet side of the heater is located where the leads/power feedthrus come out of the housing. Failure to install the heater in its proper orientation can result in heater damage and is not covered under the manufacturer's warranty.

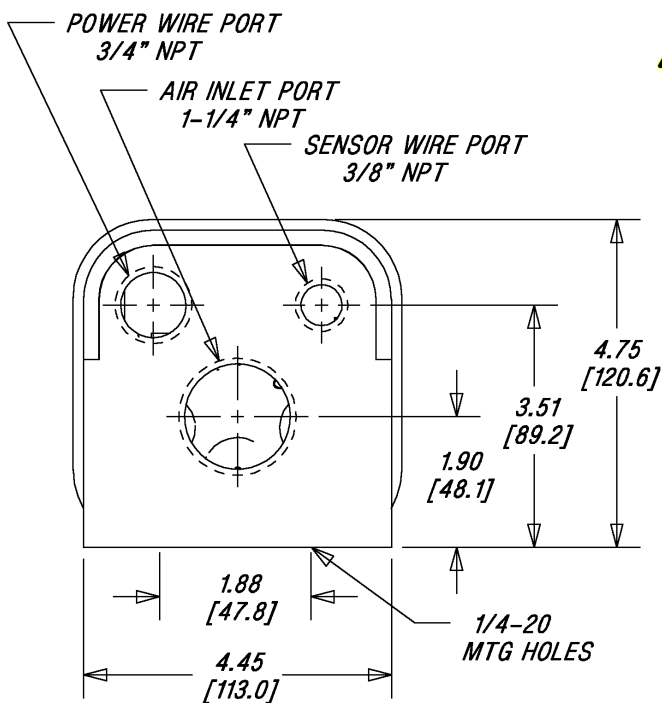
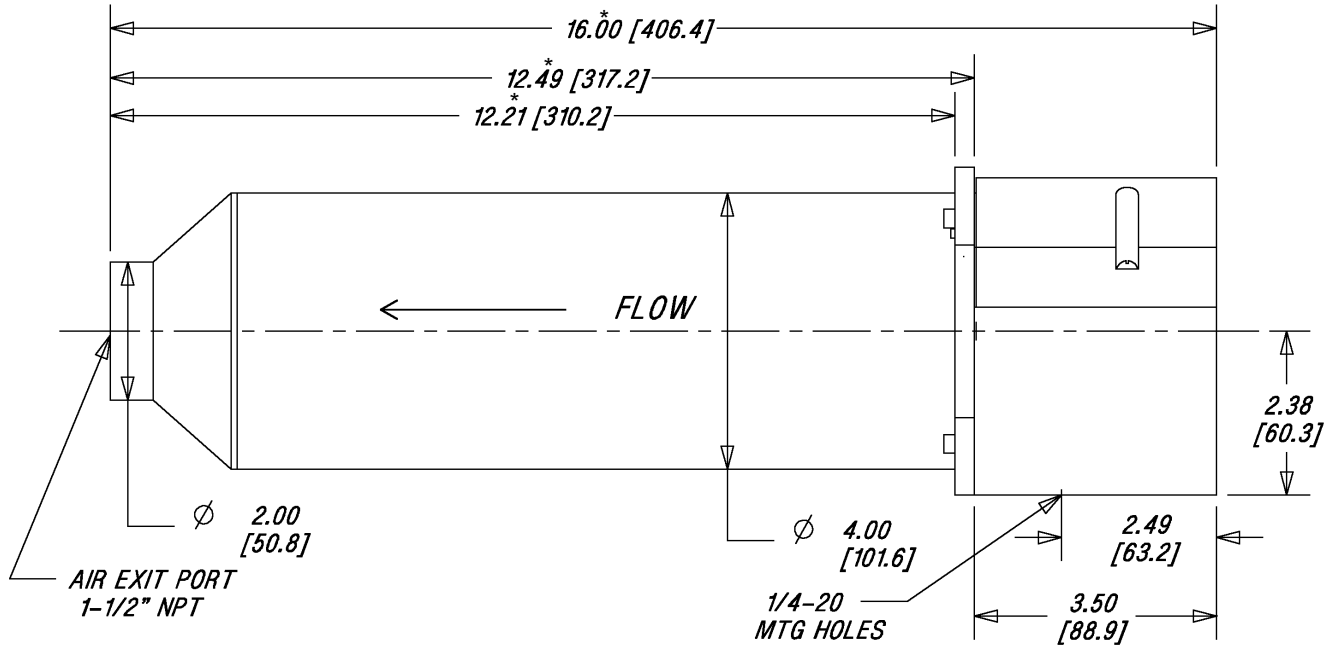

* Installation Notes:

- 18kW, 30kW & 36kW heater is 16" (406.4mm) long
- 6kW, 10kW heater is 12" (304.8mm) long
- Difference is 4" (101.6mm) shorter nozzle tube

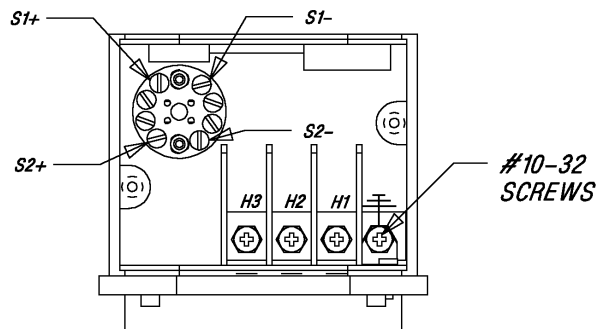

WARNING: Avoid Damage to Housing

3/8" NPT (Sensor): 4 ft-lb
 3/4" NPT (Power): 25 ft-lb
 1-1/4" NPT (Air): 7 ft-lb
 (Excessive force will crack housing and void warranty)

Precautions

1. Use filtered air. Avoid grease, oil, or oil vapors, corrosive or reactive gases which will damage heater.

Note: When using compressed air a pressure reduction valve and an oil & water separation unit should be installed to avoid contaminating the heater and reducing heater life.

2. Operate at safe voltages as shown on the Performance Curves (*see page 10*). Excess voltage will cause premature failure. (See Proper Temperature Controller Setup on Page 6 for details.)
3. Using the Max heater with the Inlet Temperature Limiter Circuit (Part #F074835) provides loss of airflow protection if wired properly. It is highly recommended that the S1 thermocouple supplied with the heater be used with a temperature limiting board to protect against low/no airflow (TUTCO SureHeat Part #074835 – set to 300°F/150°C). (See Page 7-8 for proper wiring)
 - If using other forms of control you must always have sufficient airflow through the heater before applying power. Otherwise element will overheat very quickly, and burn out.
4. If using a process air temperature thermocouple other than the supplied S2 thermocouple it is highly recommended that the S2 thermocouple be used with a temperature limiting board to protect against over temperature protection (TUTCO SureHeat Part #F074835 – set to 1205°F (652°C) for 6 & 10kW units and 1405°F (763°C) for 18, 30 & 36kW units).
5. If using closed-loop control, use a temperature controller with a fast sampling period (<500ms) and minimal overshoot.
6. Sudden applications of power can damage heater. To avoid this:



ALWAYS:

- a. Return set-point temperature to ambient (70°F/20°C) after use.
- b. Use a controlled ramp to set-point. (See Proper Temperature Controller Setup on Page 6 for details.)

Proper Temperature Controller Setup

- ✓ **Start the heater with a 0° (F or C) Set-Point (SV):** This will ensure the output signal to the power control starts off low (0% output) before the contactor is engaged and immediately applying full power.
- ✓ **Use proper closed loop control (PID) settings.** TUTCO SureHeat typically uses the following PID; Proportional (P), Integral (I) and Derivative (D); settings as a starting point for stable temperature control. Some manual tuning may be required for more precise control.

<u>Description:</u>	<u>Range:</u>	<u>Default:</u>
• (P) roportional	90-250	131
• (I) ntegral	8-20	8
• (D) erivative	0-2	2
• Scan/Refresh Rate	≤ 500mSec	200mSec

- ✓ **Incorporate a Ramp Rate for the start-up of the heater.** The slower the ramp to the final set-point the less temperature overshoot the system will incur and other related problems the system will have. Typically; TUTCO SureHeat heaters should be ramped up over a period of several minutes. The following are recommended ramp rates based on final temperature. (For custom ramp rates consult with factory)

<u>Set-Point Temperature</u>	<u>Ramp per Minute</u>
• Up to 600°F (up to 300°C)	360°F (150°C)
• 601-1000°F (301-500°C)	240°F (100°C)
• 1001-1400°F (501-760°C)	120°F (50°C)

OPTIONAL:

- ✓ **Reduce the output of the temperature controller.** Most temperature controllers default to 100% output as its high limit value. This value can be reduced as most air heaters are oversized for the application and don't need 100% power to achieve the desired output.

Installation

Securely mount the heater before wiring.



WARNING: THE INLET AIR/GAS SIDE OF THE HEATER IS THE PLASTIC HOUSING END WHERE THE POWER TERMINALS AND THERMOCOUPLE TERMINAL BLOCK IS LOCATED. INSTALLING THE HEATER IN THE WRONG ORIENTATION WILL DAMAGE THE HEATER AND CAN CREATE ADDITIONAL HAZARDS AS A RESULT. POWER CONNECTION WIRE SIZES ARE RECOMMENDED IN THE PRODUCT TABLE ABOVE. THESE ARE RECOMMENDATIONS ONLY, AND ALL LOCAL, REGIONAL AND NATIONAL ELECTRICAL CODES SHOULD BE CONSULTED.

The following is a typical and recommended setup for the Max Heater. The S1 and S2 sensors within the Max provide flexibility and safety for use with various control systems.

1. Wire heater according to diagram on Page 8. Follow applicable electrical codes when mounting and wiring system. The configuration shown is recommended by TUTCO SureHeat for safe and optimum performance.
2. Note that customer is responsible to supply wiring for **HEATER TO CONTROL**, and **CONTROL TO MAIN POWER**:
 - A) **HEATER TO CONTROL (G, H1, H2, H3) and (S1, S2)**
 - a. "K" THERMOCOUPLE WIRE must be Teflon Coated and Teflon Insulated, note RED is NEGATIVE (-).
 - i. S1 Type "K" Thermocouple Sensor on heater connects to INLET LIMIT controller. TUTCO SureHeat sets INLET TEMP LIMIT to 300°F/150°C.
 - ii. S2 Type "K" Thermocouple Sensor on heater connects to EXIT TEMP controller. TUTCO SureHeat sets EXIT TEMP ALARM to 1405°F/763°C.
 - b. HEATER TO CONTROL (G, H1, H2, H3) POWER WIRES are standard 8 to 12 Gauge, 4-wire (H1, H2, H3, Ground) electrical cable.
 - B) **CONTROL TO MAIN POWER (L1, L2, L3, GND)**
 - c. MAIN POWER WIRES are standard AWG #8 to 12 gauge, 4-wire (H1, H2, H3, Ground) electrical cable.
 - d. MAIN POWER WIRE fuses must be sized based on maximum heater current. (see heater ratings to properly size by applicable electrical codes)



Proper Torque Values for Fittings

WARNING: Avoid Damage to Housing

3/8" NPT (Sensor): 4 ft-lb

3/4" NPT (Power): 25 ft-lb

1-1/4" NPT (Air): 7 ft-lb

(Excessive force will crack housing and void warranty)

Typical Wiring:

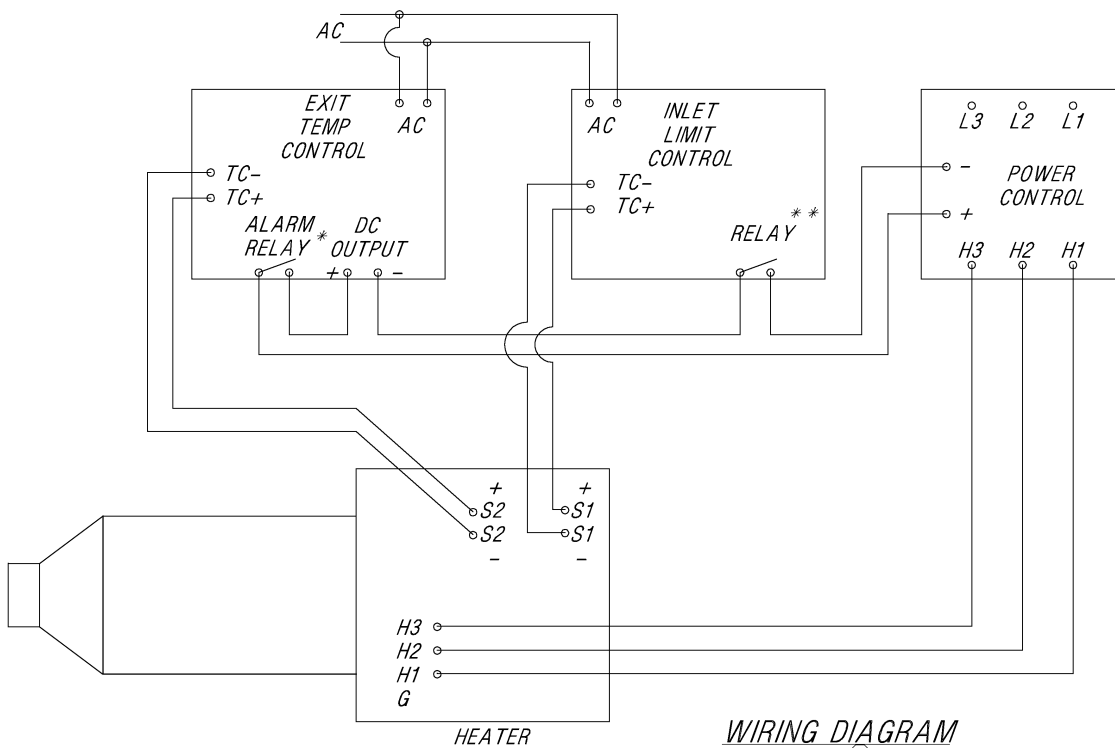
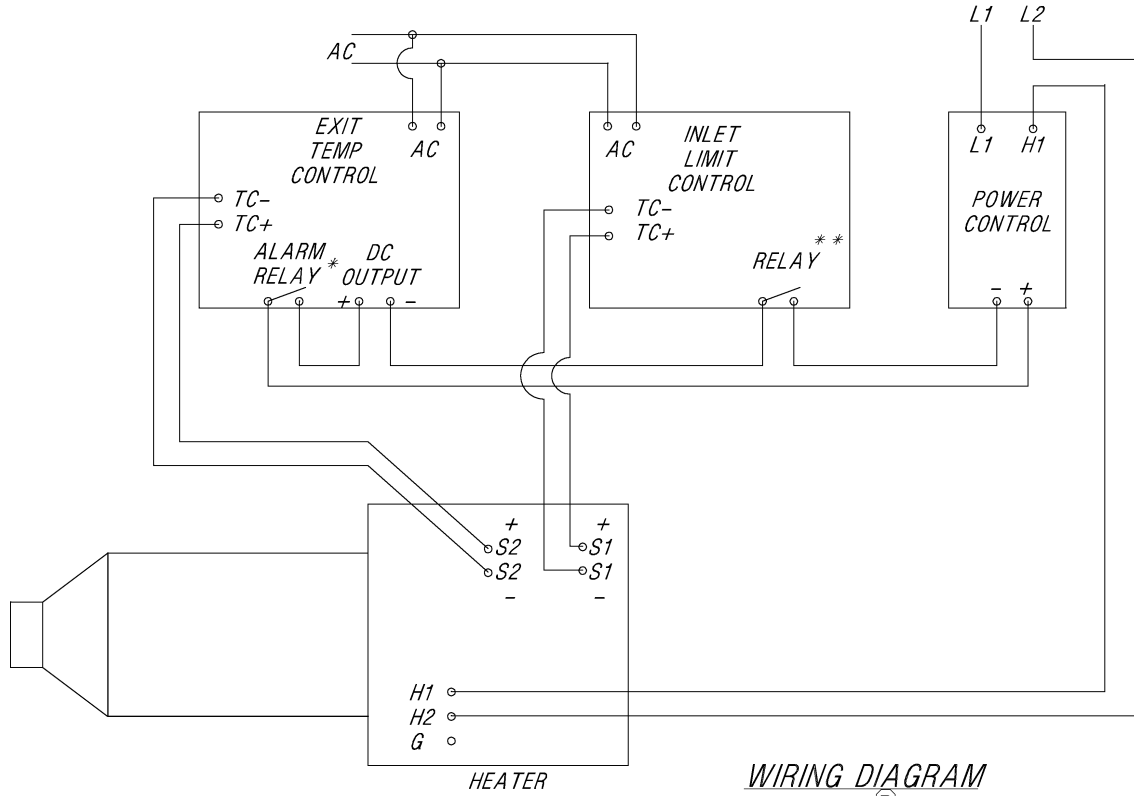

* EXIT TEMP ALARM RELAY TO OPEN AT 1405°F.
 ** INLET LIMIT RELAY TO OPEN AT 300°F.
 OTHER SETTINGS MAY DAMAGE HEATER AND VOID WARRANTY.

Operation (with Heater)

START-UP

1. Reference the Performance Curves section (see Page 10) for operational parameters before attempting to operate heater(s).
2. Connect air source to heater.
3. Turn on air and set pressure or flow to desired operating level.
4. Energize MAIN POWER line; usually via disconnect switch or circuit breaker on control cabinet.
5. During operation, with constant airflow, the exit temperature will vary only a few degrees from set point. Although the heater will not burn out with zero airflow, if the heater is operated in a vertical downward position and an airflow of 12 SCFM or less is run through the heater, the inlet temperature of the heater will exceed 300°F/150°C and the low limit controller will begin to limit power to the heater.
6. If using a closed loop system, turn on power to the temperature and power controller, then set the desired temperature on the temperature controller. If using an open loop system, increase power to the heater through the power controller until the desired temperature is attained.

SHUT-DOWN

1. Return set-point temperature on temperature controller device to ambient (70°F/20°C)
2. Turn off MAIN POWER line via disconnect switch or circuit breaker.
3. Allow air to continue to flow for a minimum of 1 minute or until exit air temperature is 300°F/150°C or less for safety. Continue airflow longer as necessary to prevent burn hazard to personnel.
4. Turn off air to the system.

Performance Curves

The attached performance curves show exit air temperatures at different airflows and voltages. Pressure readings (longer dashed lines) are measured at the inlet to the heater with no entrance or exit restrictions. Solid lines indicate safe, normal-life operating conditions. The shorter dash lines indicate marginal, shorter-life operating conditions leading to premature burnout. With a known flow (or pressure) at the heater entrance, follow the flow (or pressure) line across until it meets the desired temperature curve. Drop a line straight down to intersect the x-axis. This point, along the “Heater volts – true RMS” axis, represents the voltage required to generate the desired exit air temperature at the chosen flow rate (inlet pressure).

Max Maximum Performance Curve

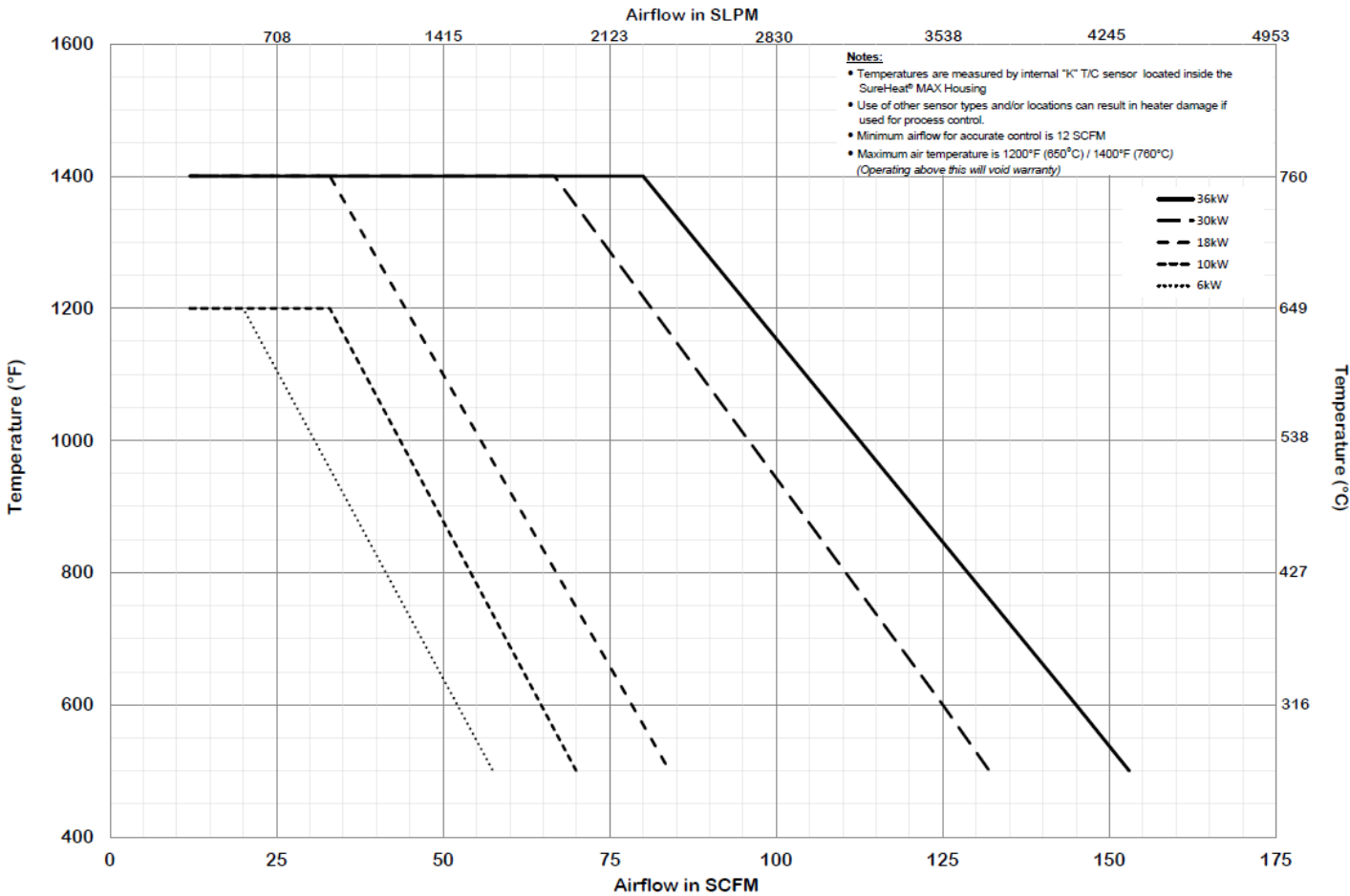

Temperature measured by the internal S2 “K” thermocouple
 Minimum recommended airflow is 12 SCFM (340 SLPM)

Max Performance Curve – 6kW

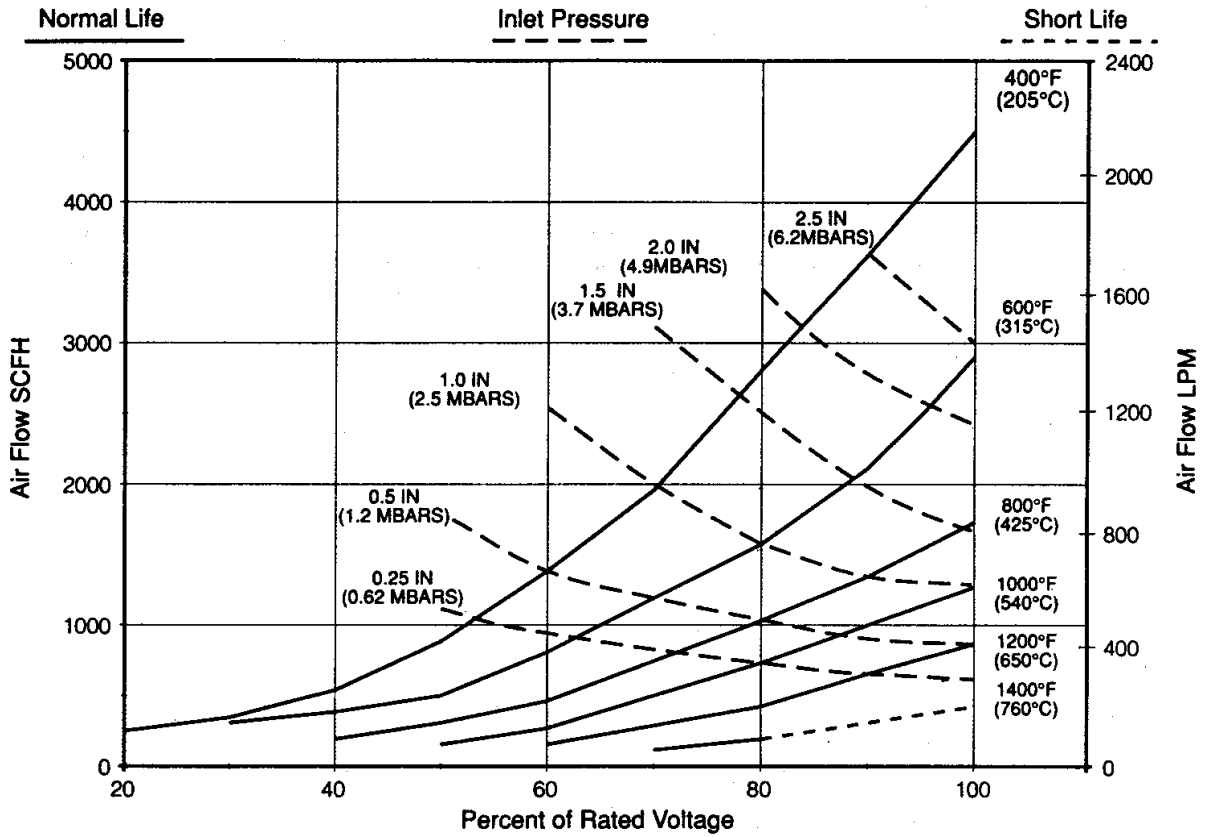

Max Performance Curve – 10kW

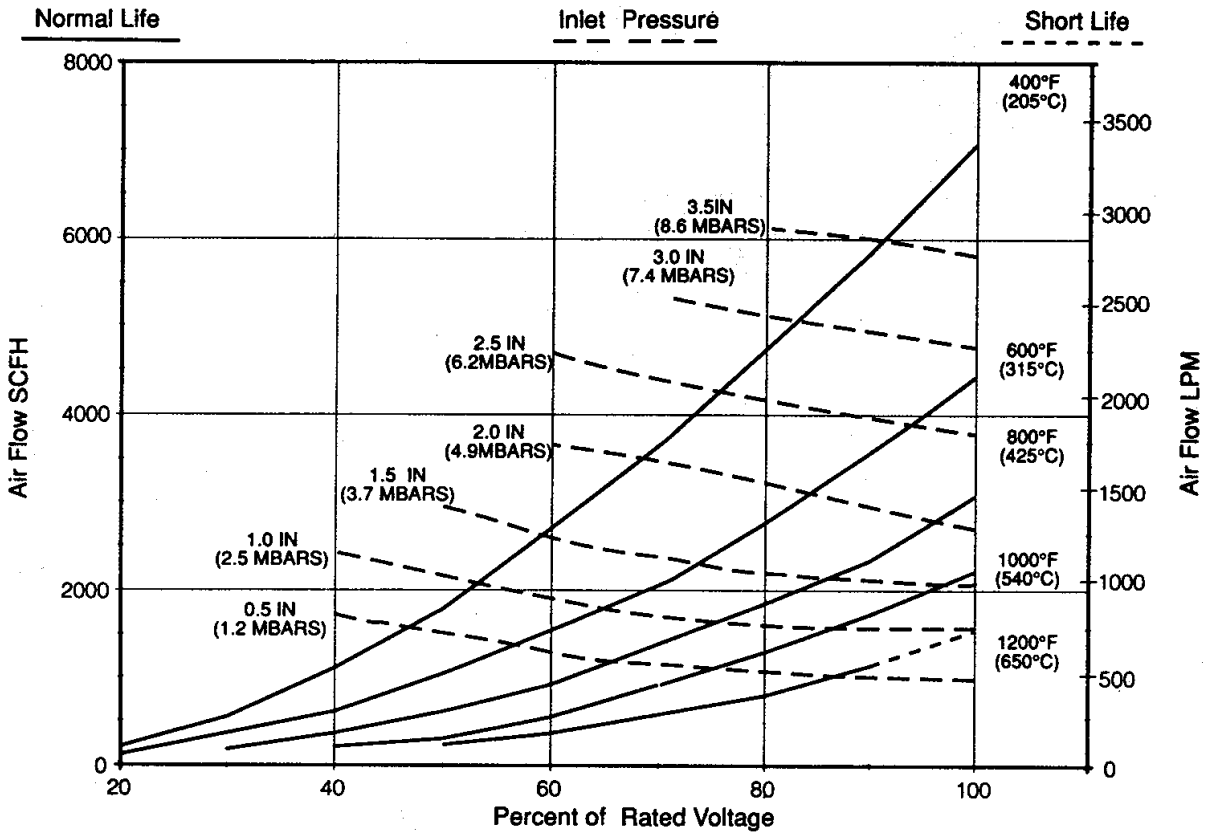

Max Performance Curve – 18kW

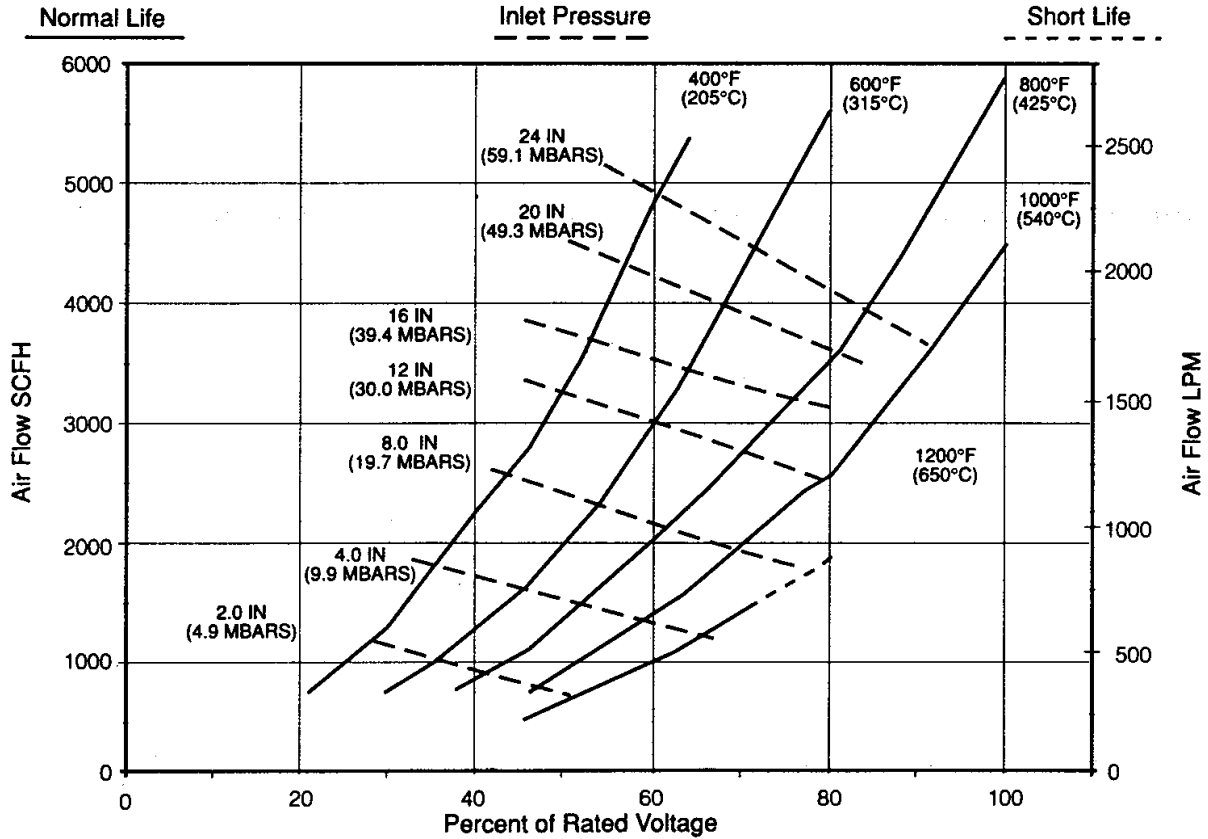

Max Performance Curve – 36kW

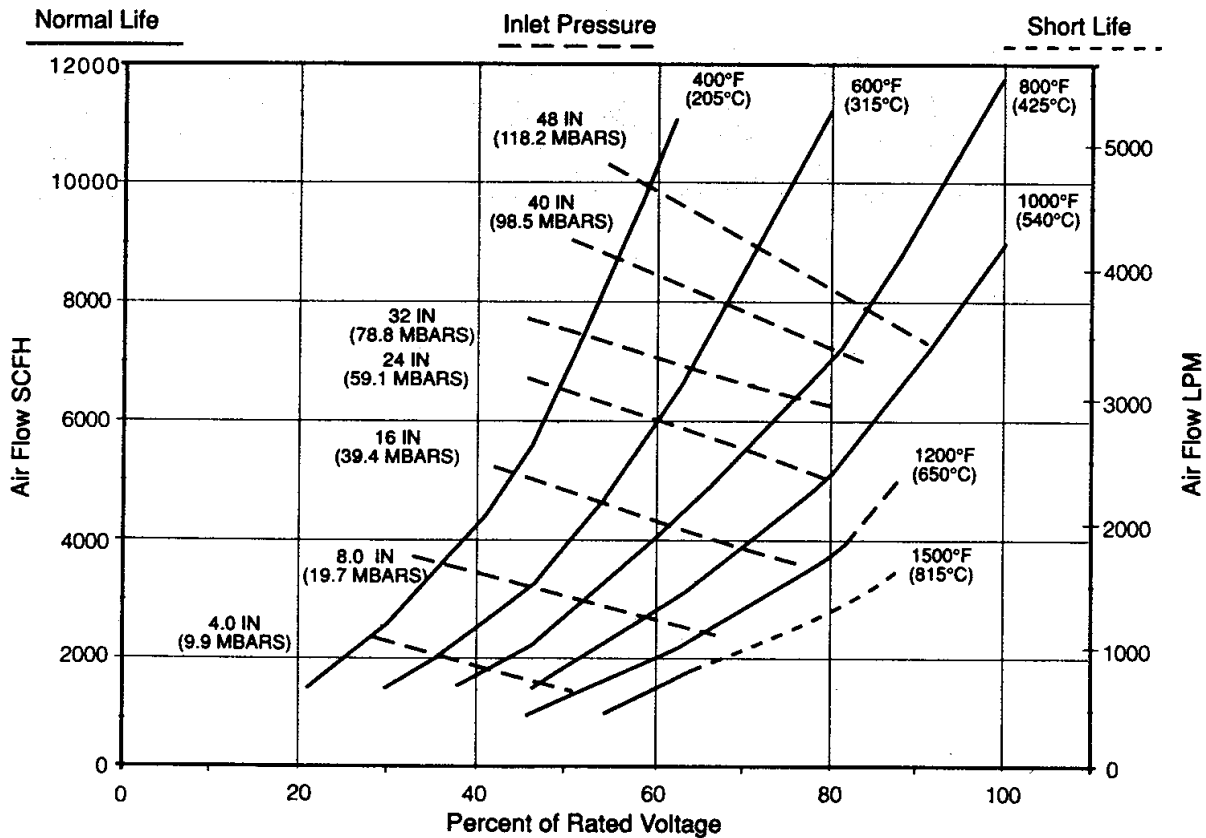

Troubleshooting and Replacing Heaters

1. Note that "TYPICAL" Element Life is APPROXIMATELY 5000 hours. This is based on heater element operating at or below temperatures shown on PERFORMANCE CURVE(S). In addition to normal end of life, elements can fail due to mechanical damage, or problems with the control system.
2. If an element has failed prematurely, it should be inspected to determine the cause of the element failure.
3. When replacing or troubleshooting heaters, turn off power to the system and be sure to follow lock-out/tag-out procedures.
 - a. For Troubleshooting Heater
 - i.) Use multi-meter to check continuity between:
 1. Power terminals: H1-H2, H2-H3, and H1-H3
 2. Thermocouples: Positive (+ yellow) to Negative (- red)
 - ii.) If there is continuity on all above tests, check system wiring:
 1. Crossed thermocouple wires.
 2. Reversed thermocouple wire polarity – Note: RED is NEGATIVE (-).
 3. Verify inlet air temperature is below set point on INLET TEMPERATURE controller.
 - iii.) If there is no continuity on any test, then contact your local TUTCO SureHeat representative for assistance.
4. Remove entire heater assembly from system. Internal components are typically not replaceable.
5. Reconnect thermocouples, power and ground wires for new/replacement heater.
6. Attach any covers and operate heater per operating manual.

Element Life Curve

(This is taken from published information provided by the element wire manufacturer. It is considered typically and not a guaranteed life)

The life of a TUTCO SureHeat heater is directly based on the temperature of the filament wire. The curve below shows that 5000 hours of life can be obtained by maintaining a filament temperature below 1900°F/1038°C. Also note that the element does not fail until it reaches more than 2200°F/1204°C.

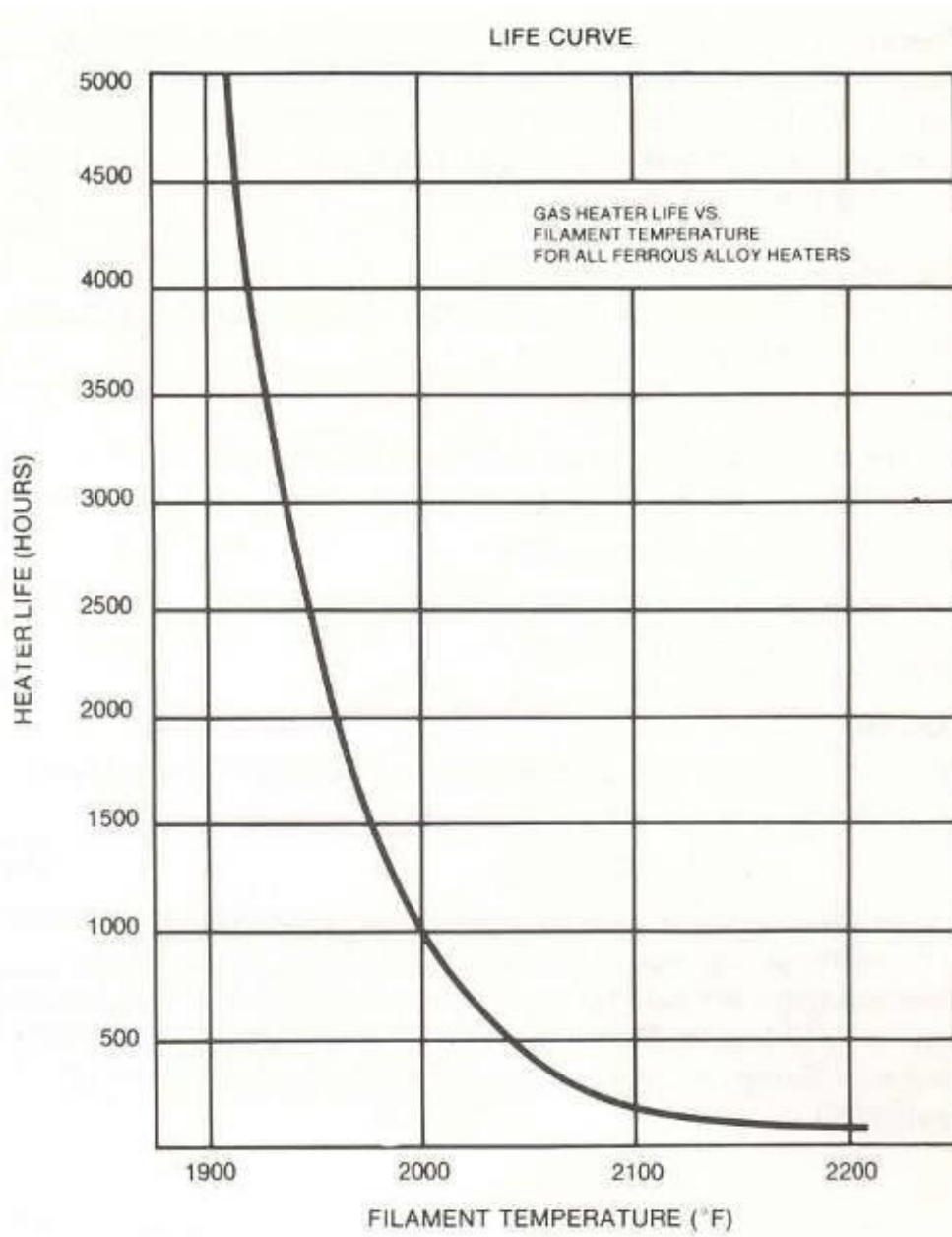

Limited Warranty

TUTCO SureHeat warrants that all products to be delivered hereunder will be free from defects in material and workmanship at the time of delivery. TUTCO SureHeat's obligation under this warranty shall be limited to (at its option) repairing, replacing, or granting a credit at the prices invoiced at the time of shipment for any of said products. This warranty shall not apply to any such products which shall have been repaired or altered, except by TUTCO SureHeat, or which shall have been subjected. TUTCO SureHeat shall be liable under this warranty only if (A) TUTCO SureHeat receives notice of the alleged defect within sixty (60) days after the date of shipment; (B) the adjustment procedure hereinafter provided is followed, and (C) such products are, to TUTCO SureHeat's satisfaction, determined to be defective.

THE WARRANTY SET FORTH IN THE PRECEDING PARAGRAPH IS EXCLUSIVE AND IN LIEU OF ALL OTHER WARRANTIES, EXPRESS OR IMPLIED, INCLUDING, WITHOUT LIMITATION, ANY IMPLIED WARRANTY OF FITNESS FOR A PARTICULAR PURPOSE OR OF MERCHANTABILITY.

The information contained in this manual is based on data considered to be true and accurate. Reasonable precautions for accuracy has been taken in the preparation of this manual, however TUTCO SureHeat assumes no responsibility for any omissions or errors, nor assumes any liability for damages that may result from the use of the product in accordance with the information contained in this manual.

Please direct all warranty/repair requests or inquiries to the place of purchase, and provide the following information, in writing:

- (A) Order number under which products were shipped
- (B) Model/Serial Number of product
- (C) Reason for rejection

PRODUCTS CAN NOT BE RETURNED TO TUTCO SUREHEAT WITHOUT AUTHORIZATION.

Replacement, repair, or credit for products found to be defective will be made by the place of purchase. All products found to be not defective will be returned to the Buyer; transportation charges collect or stored at Buyers expense.

The technical data and specifications supplied in this operating manual are subject to change without prior notice. Contact TUTCO SureHeat for additional assistance.

TUTCO SureHeat • 129 Portsmouth Avenue, Suite A • Exeter, NH 03833 USA
Phone: 800-258-8290 or 603-418-7662
Website: www.tutcosureheat.com E-mail: support@tutcosureheat.com